

ECU-SF, EXH-SF and EXU-S Technical Data

Low Lift Pallet Trucks with Driver's Stand-On Platform

ECU-SF 20

EXH-SF 20/Li-Ion

EXH-SF 25/Li-Ion

EXU-S 22/Li-Ion

EXU-S 24/Li-Ion





Distinguishing marks	1.1		Manufacturer	STILL	STILL	STILL	STILL	STILL			
	1.2		Manufacturer's type designation	ECU-SF	EXH-SF 20/Li-Ion	EXH-SF 25/Li-Ion	EXU-S 22/Li-Ion	EXU-S 24/Li-Ion			
Weights	1.3		Drive	Hinged stand-on platform	Hinged stand-on platform	Hinged stand-on platform	Rear access	Side access	Rear access	Side access	
	1.4		Operator type	Electric	Electric	Electric	Electric	Electric	Electric	Electric	
	1.5		Capacity/load	Standing/pedestrian	Standing/pedestrian	Standing/pedestrian	Standing	Standing	Standing	Standing	
	1.6		Capacity/load	Q	kg	2000	2500	2200	2400	2400	
	1.7		Load centre distance	c	mm	600 ¹	600	600	600	600	
	1.8		Load distance	x	mm	872 ⁴	895 ⁴	895 ⁴	890 ²	872 ²	
	1.9		Wheel base	y	mm	1304	1408 ²	1408 ²	1617	1599	
	2.1		Service weight (incl. battery)		kg	654	875	875	1120	1150	
	2.2		Axle load, laden	drive end/load end	kg	1676/978	983/1920	983/1920	1500/1820	1317/2233	
2.3		Axle load, unladen	drive end/load end	kg	79/575	710/165	710/165	310/210	918/232		
Tyres/chassis	3.1		Tyres		Polyurethane	Polyurethane	Polyurethane	Polyurethane	Polyurethane		
	3.2		Tyre size	drive end	mm	∅ 230 x 75	∅ 230 x 90	∅ 230 x 90	∅ 250 x 100	∅ 250 x 100	
	3.3		Tyre size	load end	mm	∅ 85 x 90 (∅ 85 x 90) ¹	∅ 85 x 85 (∅ 85 x 60) ¹	∅ 85 x 85 (∅ 85 x 60) ¹	∅ 85 x 100 (∅ 85 x 80) ¹	∅ 85 x 100 (∅ 85 x 80) ¹	
	3.4		Support rollers	drive end	mm	2x ∅ 100 x 40	2x ∅ 125 x 60	2x ∅ 125 x 60	2x ∅ 140 x 54	2x ∅ 140 x 54	
	3.5		Number of wheels (x = driven)	drive end/load end		1x-2/2	1x + 2/4	1x + 2/4	1x + 2/4	1x + 2/4	
	3.6		Tread	drive end/load end	b ₁₀ /b ₁₁	mm	398/485	502/380	502/380	470/388	
Dimensions	4.4		Lift	h ₃	mm	135	125	125	130	130	
	4.8		Standing height (platform)	h ₇	mm	170	220	220	225	225	
	4.9		Tiller handle height in driving position	min./max.	h ₁₄	mm	1145/1342	1210/1440	1210/1440	1030	
	4.15		Fork height, lowered		h ₁₃	mm	85	86	86	85	
	4.19		Overall length	platform closed/open	l ₁	mm	1854/2180	1957/2395 ⁵	1957/2395 ⁵	2415 ⁶	2487 ⁶
	4.20		Length including fork backs	platform closed/open	l ₂	mm	704/1030	800/1238 ⁵	800/1238 ⁵	1225 ⁶	1297 ⁶
	4.21		Total width		b ₁	mm	710	720	720	720	
	4.22		Fork dimensions	DIN ISO 2331	s/e/l	mm	50/162/1150	165/55/1150	165/55/1150	55/175/1190	61/172/1190
	4.25		Overall fork width		b ₅	mm	560	560	560	560	
	4.32		Ground clearance, centre of wheel base		m ₂	mm	33	30	30	30	
	4.34		Working aisle width with 800 x 1200 pallet lengthways	platform open	A _{st3}	mm	2622 ²	2844 ^{2,5}	2844 ^{2,5}	2812 ^{2,6}	2882 ^{2,6}
	4.34.1		Working aisle width with 1000 x 1200 pallet crossways	platform open	A _{st}	mm	2703 ²	2926 ^{2,5}	2926 ^{2,5}	2894 ^{2,6}	2964 ^{2,6}
	4.35		Turning radius	platform open	W _a	mm	1904 ²	2140 ^{2,5}	1700/2140 ^{2,5}	2105 ^{2,6}	2175 ^{2,6}
	Performance	5.1		Travel speed	laden/unladen	km/h	6/6 (7.5 ³)	6/6 (8/8, 10/10) ⁴	12/10 (14/10) ⁴	10/12	9/12
5.2		Lift speed	laden/unladen	m/s	0.034/0.045	0.05/0.06	0.05/0.06	0.043/0.062	0.043/0.062		
5.3		Lowering speed	laden/unladen	m/s	0.045/0.045	0.1/0.08	0.1/0.08	0.068/0.065	0.068/0.065		
5.8		Max. gradeability	laden/unladen	%	0.7/10.2	12/20	12/20	10/15	9.3/15		
5.10		Service brake			Electromagnetic	Electromagnetic	Electromagnetic	Electromagnetic	Electromagnetic		
Electric engine	6.1		Drive motor, rating S2 60 min		kW	1.2	2.3	3.0	3.0	3.0	
	6.2		Lift motor, rating at S3 15%		kW	1.2	1.2	1.5	2.2	2.2	
	6.3		Battery according to DIN 43531/35/36; A, B, C, no			DIN 43535 B	DIN 43535 3PzS	DIN 43535 3PzS	No	No	
	6.4		Battery voltage/nominal capacity K _s		V/Ah	24/250	24/375	24/375	24/465 // Li-Ion 24/410	24/465 // Li-Ion 24/410	
	6.5		Battery weight ±5% (depends on make)		kg	220	290	290	405	405	
	6.6		Energy consumption according to VDI cycle		kWh/h	1.06	0.45	0.5 (0.56) ⁴	1.05	1.07	
Misc.	8.1		Drive control			Pulse control	AC control	AC control	AC control		
	8.4		Sound level at driver's ear		dB(A)	<70	62	62	<65	<65	

¹ With tandem load rollers
² Elevated initial lift, lowered initial lift +70 mm
³ With optional side bars
⁴ With Power Plus
⁵ With 4PzS batteries +75 mm
⁶ With 4PzS batteries +85 mm

Turning Radius

Turning radius W_a for determining the working aisle width with load distance x, elevated initial lift and battery in accordance with VDI 6.4

	Fork length <i>l</i> in mm	Distance x in mm	Distance y in mm	Turning radius W _a in mm	
				platform closed	platform open
ECU-SF 20	800	522	952	1247	1554
	980	702	1132	1427	1734
	1150	872	1302	1597	1904
	1450	1172	1602	1897	2204
	1600	1322	1752	2047	2354
	EXH-SF 20/25	1000	745	1258	1550
1150		895	1408	1700	2140
1200		945	1458	1750	2190
1450		995	1508	1800	2440
1600		1345	1858	2150	2590
2150		1495	2008	2300	2740
2400 ¹		1770	2283	2575	3015
2400 ²	2145	2658	2950	3390	

	Fork length <i>l</i> in mm	Distance x in mm	Distance y in mm	Turning radius W _a in mm	
				Rear access	Side access
EXU-S 22	990	690	1284	1905	1975
	1190	890	1484	2105	2175
	1600	1300	1894	2315	2585
	990	672	1266	1887	1957
EXU-S 24	1190	872	1466	2087	2157
	1600	1282	1876	2497	2567
	2390 ¹	1714	2308	2929	2999
	2390 ²	2072	2666	3287	3357

¹ Wheel base suitable for lifting 2 Euro pallets lengthways
² Wheel base suitable for lifting 3 Euro pallets crossways

ECU-SF, EXH-SF and EXU-S Low Lift Pallet Trucks with Driver's Stand-On Platform
 Technical Drawings

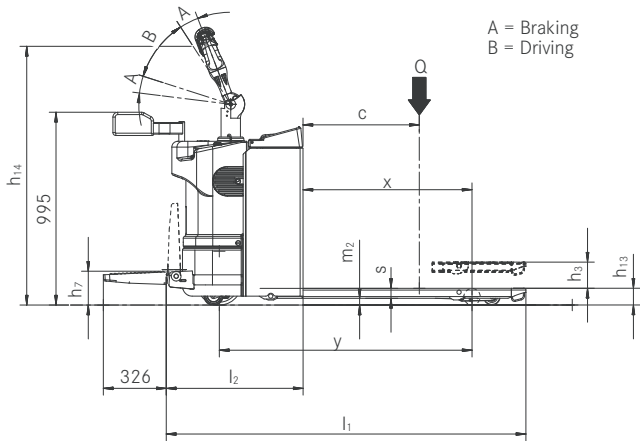

Side view ECU-SF

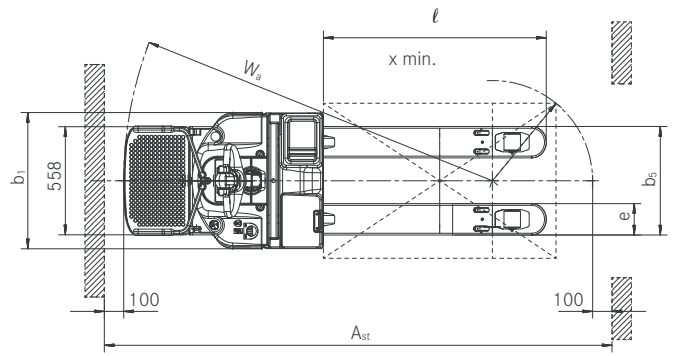

Top view ECU-SF

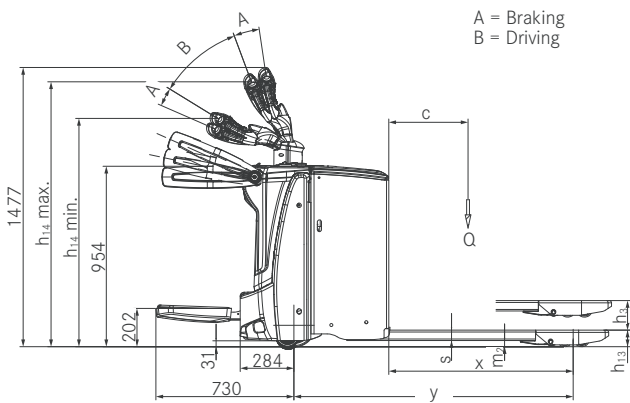

Side view EXH-SF

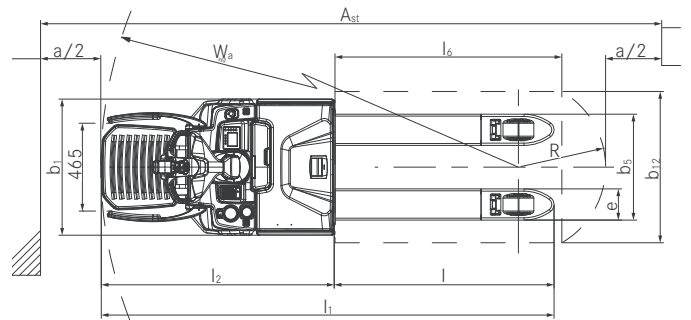

Top view EXH-SF

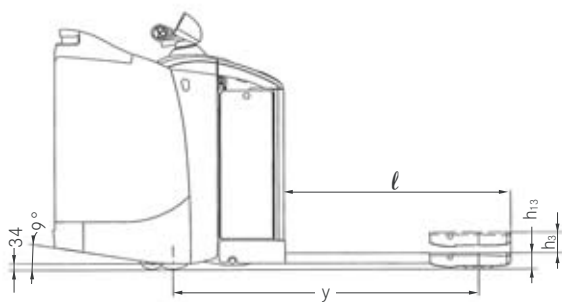

Side view EXU-S with rear access

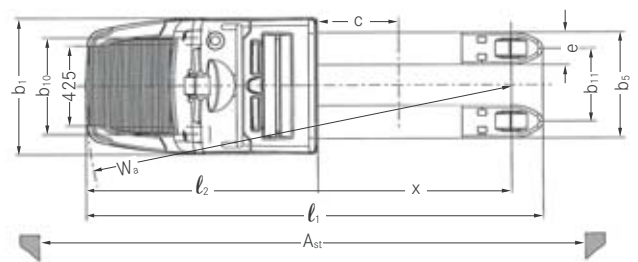

Top view EXU-S with rear access

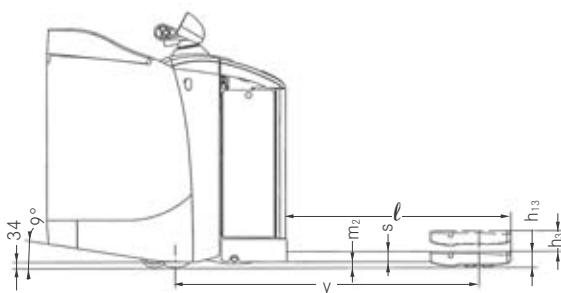

Side view EXU-S with side access

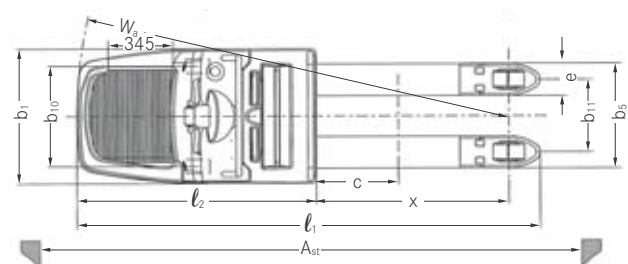

Top view EXU-S with side access

EXH-SF Low Lift Pallet Truck with Driver's Stand-On Platform
Swift and Compact



ECU-SF and EXH-SF Low Lift Pallet Trucks with Driver's Stand-On Platform Detailed Photos



Always available: sufficient energy for long operating times and the possibility of changing the battery¹



All-round safety: optional side guards can be easily and quickly lowered, keeping drivers safe and stable, and providing optimal protection in all driving situations¹



Ergonomic and intuitive operation: driving, lifting and steering processes can be controlled single-handedly by either left- or right-handed operators¹



Effective material handling: up to 2,000 kg lifting capacity and maximum speed of 7.5 km/h¹



Up to 2,500 kg lifting capacity and an impressive top speed of 14 km/h²



Adjustable side arms and air-sprung stand-on platform adjustable to individual driver weight²



Innovative battery plug lock enables fast battery replacement, without the risk of jamming²



Colour display with language-independent symbols shows all of the important functions at a glance²

¹ Here e.g. ECU-SF // ² Here e.g. EXH-SF

EXH-SF and EXU-S Low Lift Pallet Trucks with Driver's Stand-On Platform Detailed Photos



Optimum view of the fork tips allows a high and safe handling performance²



Increased operational hours thanks to fast interim charging with optional STILL Li-ion technology²



Everything within reach at all times: thanks to the STILL COCKPIT, both left and right-handed users can intuitively operate all of the truck's functions using ergonomic control elements³



Ultimate availability: either with lateral lead-acid battery changing as standard, for fast, safe replacement, or with interim charging of a lithium-ion battery³

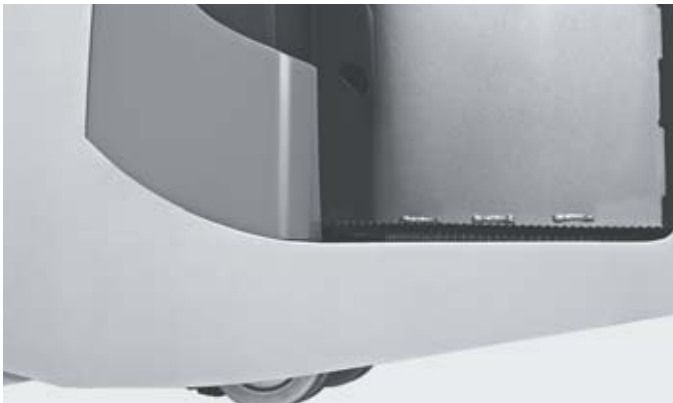

Built for ramps: slanted chassis design allows the truck to travel on ramps with a gradient of up to 9°³



Comfortable even over long distances: left-hand side access allows the driver to lean back during long stretches of driving³



Operator comfort: cushioned stand-on platform for the driver improves ability to concentrate³



High pallet reloading rate: fast and precise operation thanks to rounded fork tips for easy threading into the pallets³

² Here e.g. EXH-SF // ³ Here e.g. EXU-S

ECU-SF and EXH-SF Low Lift Pallet Trucks with Driver's Stand-On Platform Swift and Compact

Fast and safe: optional side guards can be opened and closed using just one hand

Perfect ergonomics: stand-on platform is only 170 mm high, allowing operators to easily mount and dismount

High pallet reloading rate: compact size for quick and safe operation



ECU-SF

The powerful ECU-SF low lift pallet truck by STILL features a hinged platform and a load capacity of 2,000 kg, making it the ideal choice for loading and unloading lorries and for transporting goods horizontally. This compact warehouse helper can be manoeuvred accurately and safely in narrow spaces. Its rounded forks can be easily threaded into pallets. This low-maintenance truck gets the job done reliably, from lightweight jobs over multiple shifts in the industrial sector to handling material in retail environments.

The chassis is covered with shock-resistant plastic, providing the robust truck with outstanding protection in harsh environments. With a height of only 170 mm, the platform on the ECU-SF is very low. This enables operators to quickly and safely get on and off the stand-on platform. The precise and intuitive electrical steering unit minimizes operator fatigue and enables goods to be turned around fast. The optional side bars can be opened and closed using only one hand, keeping the driver stable and safe in any driving situation.

Superb handling performance: top speed of 14 km/h and maximum lifting capacity of 2,500 kg

Back-friendly: air-cushioned stand-on platform adjustable to individual weight with adjustable side arms

Powerful driving on ramps: hydraulically sprung support wheels for best traction



EXH-SF

Speed, ergonomics, compact design – the EXH-SF pallet truck with hinged stand-on platform is the perfect combination of all these qualities. With a maximum lifting capacity of 2,500 kg and an impressive top speed of 14 km/h, the EXH-SF demonstrates superior handling power. The air-cushioned stand-on platform with integrated compressor keeps work back-friendly at all times. Due to its sprung support wheels the smart warehouse organiser crosses ramps comfortably, safely and with optimum traction. Furthermore,

the EXH-SF helps save valuable warehouse space: with a total width of just 720 mm, the pallet truck is narrower than a Europallet and can be manoeuvred precisely through the narrowest of aisles. Do you need a truck that is operational 24 hours a day? With the STILL Li-ion technology, even the shortest breaks are sufficient to charge the EXH-SF. As different battery sizes are available depending on your individual needs, any customer requirement as well as multi-shift operations can be realised.

EXU-S Low Lift Pallet Truck with Driver's Stand-On Platform Robust and Efficient

High pallet reloading rate, with a top speed of 12 km/h and compact dimensions

Increased service life: battery capacity of up to 620 Ah or optionally with lithium-ion battery of up to 410 Ah

Fast and safe: fully electric steering with electronic filtering of unwanted steering movements

Excellent manoeuvrability on ramps due to the slanted chassis



EXU-S

STILL's EXU-S series of low lift pallet trucks with driver's stand-on platform have been specially designed for the loading and unloading of HGVs using ramps. The slanted chassis prevents catching or jamming on ramp transitions and ensures swift, safe movement on ramps. With a lifting capacity of up to 2,400 kg and a top speed of 12 km/h, goods are handled quickly and efficiently. The narrow chassis measuring only 720 mm and a smooth steering system ensure a precise and safe control, even in the narrowest of aisles. With battery capacities of up to 620 Ah, the EXU-S is the long-distance runner of

logistics, capable of working shift after shift. With the optional STILL Li-ion technology, quick interim charging is sufficient to keep the pallet truck ready to go around the clock.

Two different platform concepts are available for the trucks. The side access model provides optimal driver comfort and safety for handling work and horizontal transport over long distances, while the rear access model is the ideal choice for any application that requires the operator to regularly get on and off the truck.

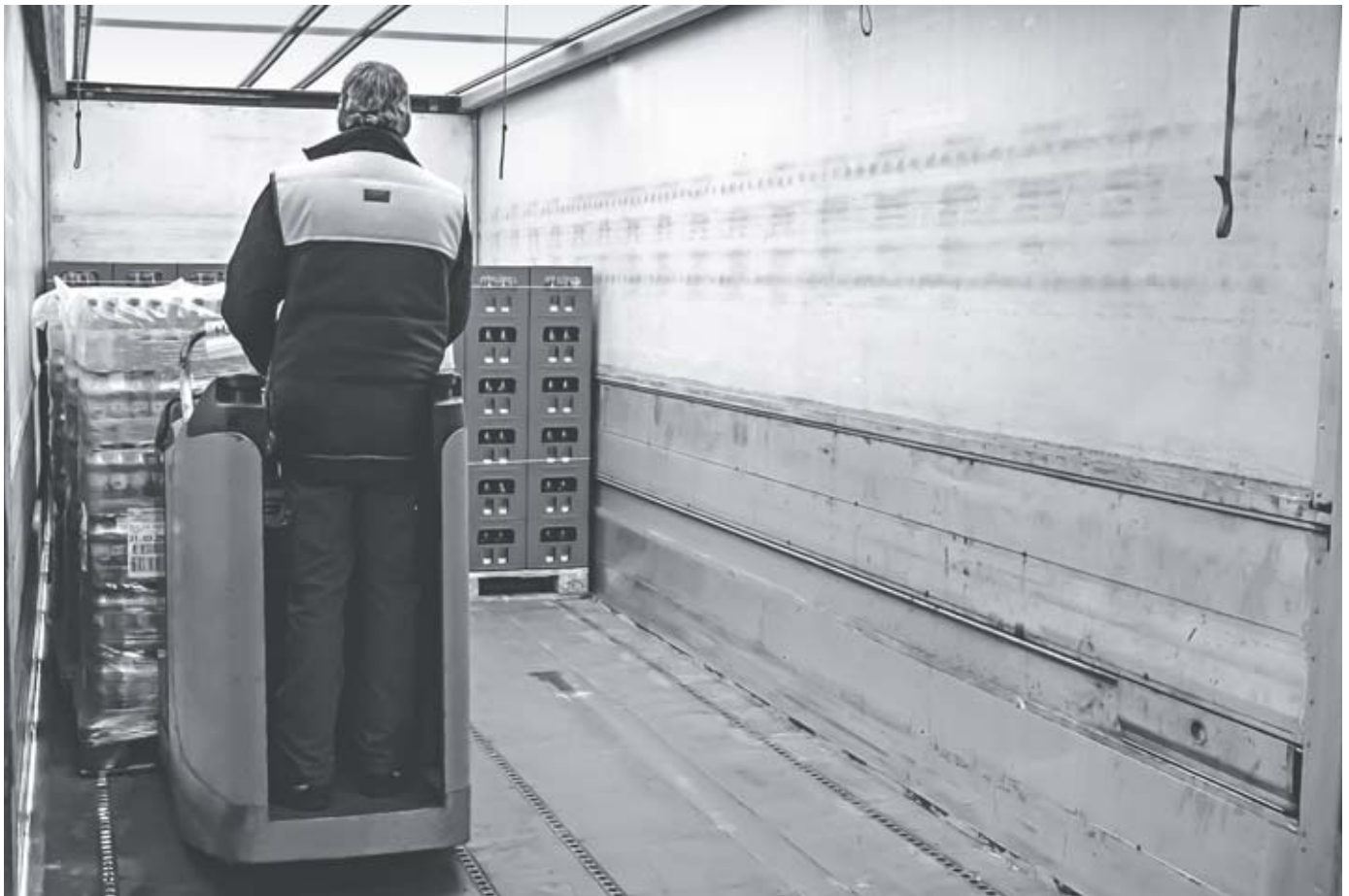

ECU-SF, EXH-SF and EXU-S Low Lift Pallet Trucks with Driver's Stand-On Platform Extensive Equipment

Power

- Strong and speedy: up to 2,500 kg lifting capacity and maximum speed of 14 km/h
- Powerful, reliable and low-maintenance AC drive motor
- The right driving programme for all situations: select maximum handling capacity or maximum efficiency: BOOST or ECO
- Always ready to go: a battery capacity of up to 500 Ah and the optional STILL Li-ion battery keeps the truck operational around the clock
- Powerful and safe on ramps: sprung support wheels ensure maximum traction

Precision

- Fatigue-free operation thanks to precise and intuitive electrical steering unit
- Best view: free view of the fork tips facilitates precise work
- Important information at a glance: colour display with language-independent icons

Ergonomics

- Back-friendly: air-cushioned stand-on platform can be adjusted to individual driver's weight
- Ergonomic and intuitive operation: driving, lifting and steering processes can be simultaneously controlled by left- or right-handed operators using only one hand
- Easy and quick battery changing: lateral battery changing option for greater operational hours with top safety
- Safe operation: height-adjustable side arms for optimum lateral support

Compactness

- High pallet reloading rate: compact dimensions allow for quick and safe operation
- Flexible loading: optional in-built charger allows decentralised loading processes
- Optimal utilisation of storage area: compact dimensions and high manoeuvrability facilitate narrow working aisles

Safety

- Safe around corners: Curve Speed Control automatically adapts speed to the steering angle when cornering
- Swift and safe: optional combi-tiller dynamically adjusts the distance between driver and truck and increases the maximum speed in pedestrian operation to 6 km/h
- All-round safety: height-adjustable side guards keep the driver safe and stable, and provide optimal protection in all driving situations
- Maximum driver protection: sensitive and optimally positioned impact plate
- Accidental roll-back eliminated: automatic stop function also on ramps

Environmental Responsibility

- Active environmental awareness: emission-free operation
- Environmentally-friendly and economical: energy efficient ECO driving programme
- Over 95 percent of all materials used are recyclable
- Low operating costs: low energy consumption and long maintenance intervals



ECU-SF, EXH-SF and EXU-S Low Lift Pallet Trucks with Driver's Stand-On Platform Equipment Variants



	ECU-SF 20	EXH-SF 20	EXH-SF 25	EXU-S 22	EXU-S 24	
General	Integrated storage options	●	●	●	●	
	Control element assembly suitable for both left and right-handed operators	●	●	●	●	●
	LED-battery status display and operating hours meter	●	○	○	●	●
	Colour display and control unit for selecting the driving programme, including Blue-Q	—	●	●	—	—
	Cold storage version	—	○	○	○	○
	Powerful three phase drive motor for very low maintenance costs	●	●	●	●	●
	Side protection bars	○	○	●	—	—
	Side protection panel	—	—	—	●	●
	Accessories bracket on the drive side	—	○	○	○	○
	Hinged Platform	●	●	●	—	—
	Mechanically sprung stand-on platform	●	○	—	●	●
	Air-sprung stand-on platform	—	●	●	—	—
	Air-sprung stand-on platform with built-in compressor for suspension adjustment	—	○	○	—	—
	Initial lift	●	●	●	●	●
	Adjustable DIN-A4 writing pad	—	○	○	○	○
	Preparation Material Management System (MMS) and data transfer	—	○	○	○	○
	Tyres	Drive wheel tyres, polyurethane	●	●	●	●
		Drive wheel tyres, polyurethane, profiled	—	○	○	○
Drive wheel tyres, solid rubber		○	○	○	—	—
Drive wheel tyres, solid rubber, profiled		—	○	○	—	—
Load roller tyres, polyurethane, single		●	●	●	○	○
Load roller tyres, polyurethane, tandem		○	○	○	●	●
Safety	Access authorisation (key)	●	●	●	—	—
	Access authorisation (digicode)	—	○	○	●	●
	FleetManager: access authorisation, shock detection, reports	—	○	○	○	○
	Curve Speed Control: speed reduction when driving around corners	—	●	●	●	●
	Combi-tiller: variable tiller length for an adequate distance between driver and equipment	—	○	○	—	—
	Headlights	—	○	○	—	—
	STILL Safety Light	—	○	○	—	—
	Load backrest	—	○	○	○	○
Battery	Sheet steel battery cover	—	●	●	●	●
	Battery compartment for battery up to 250 Ah, for changing batteries with a crane	●	○	○	—	—
	Battery compartment for 300-375 Ah battery, for changing batteries with a crane	○	●	●	—	—
	Battery compartment for 400-500 Ah battery, for changing batteries with a crane	—	○	○	●	●
	Battery compartment for battery up to 250 Ah, for changing batteries with a roller track and changing frame	—	○	○	—	—
	Battery compartment for 300-375 Ah battery, for changing batteries with a roller track and changing frame	—	○	○	—	—
	Battery compartment for 400-500 Ah battery, for changing batteries with a roller track and changing frame	—	○	○	●	●
	Battery compartment for battery up to 620 Ah, for changing batteries using a roller track and changing frame	—	—	—	○	○
	Built-in charger for changing batteries using a crane	○	○	○	—	—
	205 Ah STILL Li-Ion battery	—	○	○	○	○
	410 Ah STILL Li-Ion battery	—	○	○	○	○
Built-in charger for Li-ion batteries	—	○	○	○	○	

● Standard ○ Option — Not available

STILL GmbH
Berzeliusstraße 10
D-22113 Hamburg
Tel.: +49 (0)40/73 39-20 00
Fax: +49 (0)40/73 39-20 01
info@still.de

For further information please visit:
www.still.eu

STILL is certified in the following areas: Quality management, occupational safety, environmental protection and energy management.

